

Table with drawn metal frame held together with visible burnished screws. Decorative brass inserts. Float glass table top.

In 1968 this was the first piece manufactured by Simon: the first solid piece in the "Ultrarazionale" collection, which came into being with the aim of breaking away from the strict limits of Rationalism, which by now had become nothing more than a mannered phenomenon still rehashing the same tired trends of a movement past its prime both in historical and poetical terms.

### Gallery



## Dimensions

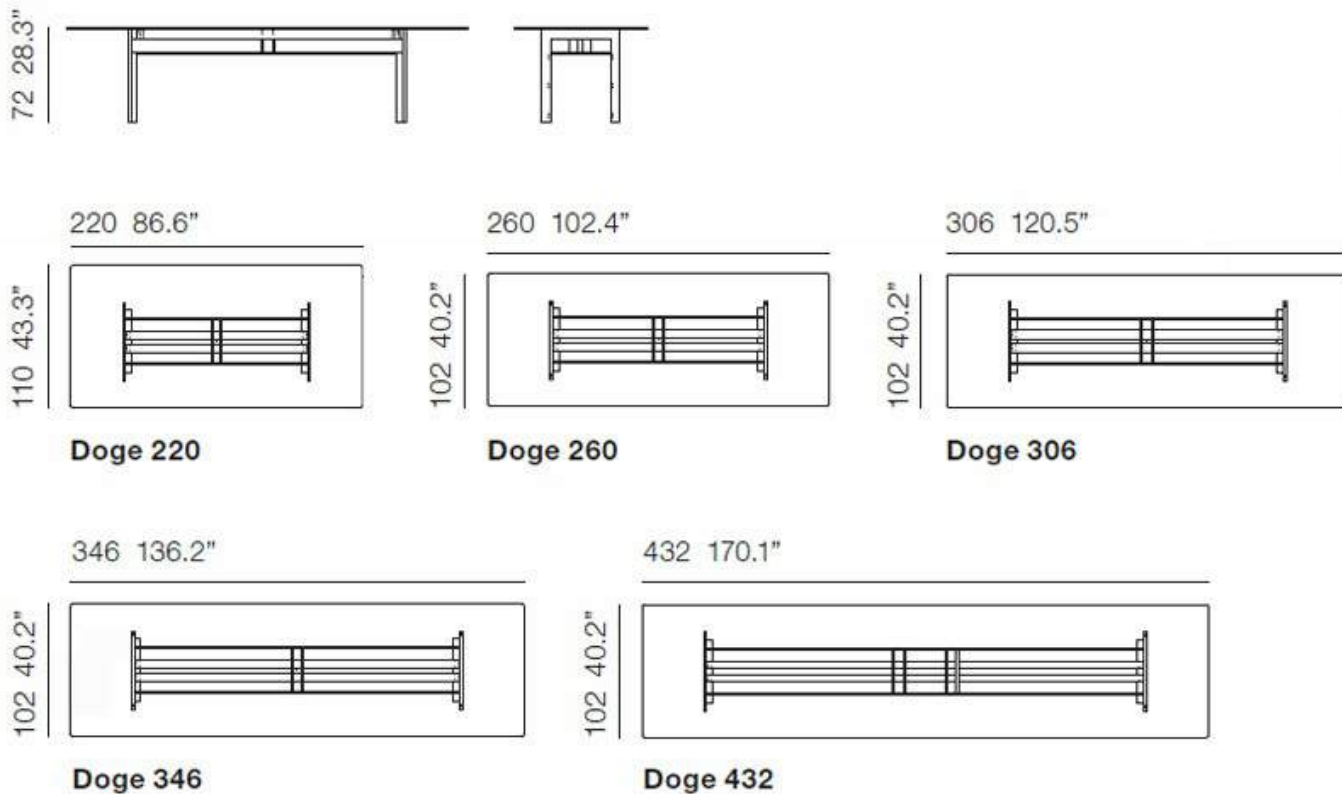

## Authenticity

All the models in the Cassina collection, by merit of their artistic content and particular creative character, are protected by copyright, a legal institution that is universally recognised and safeguarded; legal protection is assured for the whole life-span of the author and for 70 years after his/her death (or the death of the last surviving co-author).

## Designer



**Carlo Scarpa**

From architecture to works in glass, from design projects to preparing museum exhibitions, the work of Carlo Scarpa has always stood out in the unmistakable way in which it manages to bring together his love for materials, his attention to detail and his masterly elaboration of organic and Wrightian poetics. Architect, designer and artist, Scarpa left the Venice Academy of Art in 1926 and began professional work, but continued to visit craftsmen's workshops and Venetian master glassworkers. For twenty years, right up until the second half of the Forties, he received numerous commissions to design, convert prepare buildings.