



Designed by
Ron Gilad, 2016

ENQUIRIES
info@contextgallery.com

Tel. 404. 477. 3301
Tel. 800. 886.0867

contextgallery.com

Novità/News/Neuheit/
Nouveauté 2019

083 Deadline

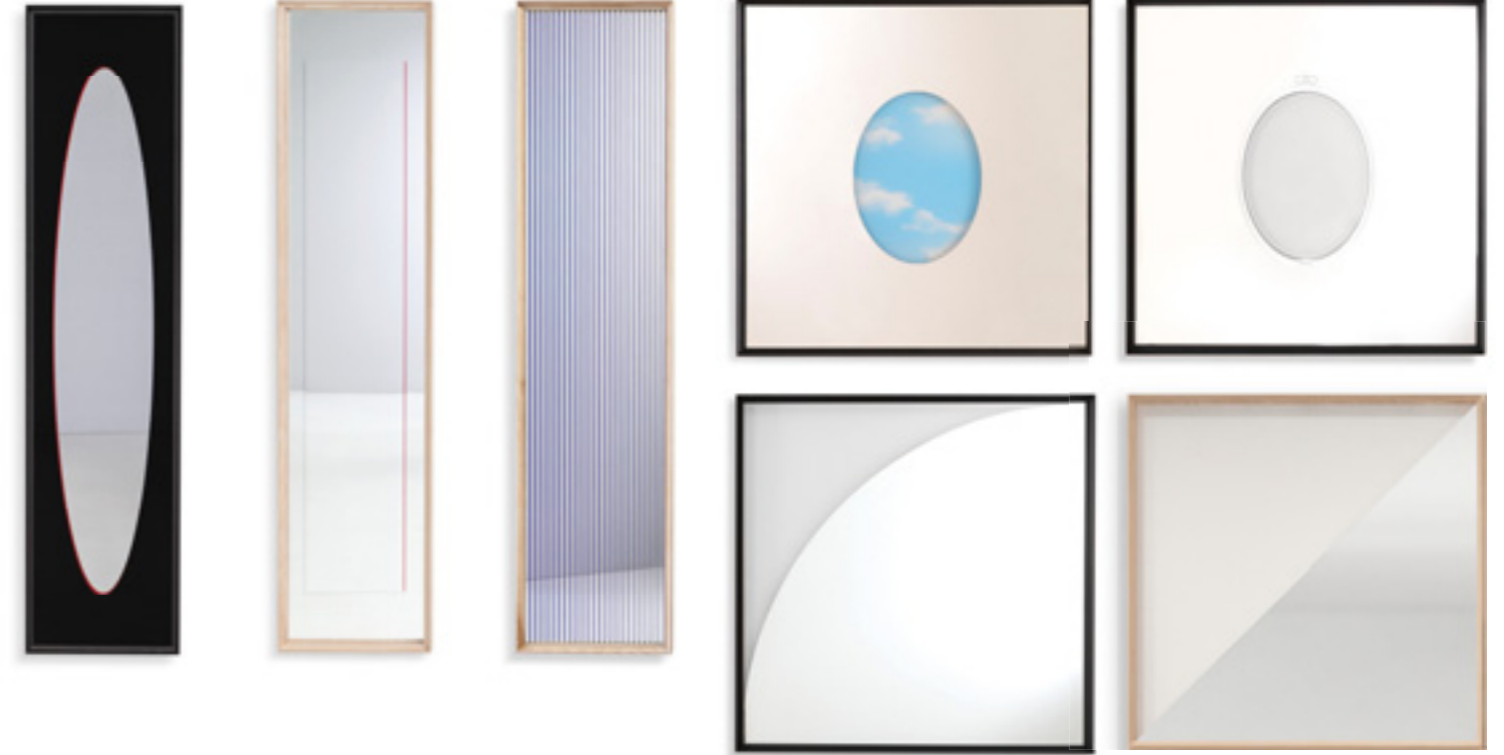

ITA

Una collezione di specchi, oggetti ibridi di grande maestria costruttiva, ideati da Ron Gilad coniugando ingegneria costruttiva e alta ebanisteria. 16 esemplari unici, ciascuno inserito in una cornice di frassino bianco o nero, con superfici e forme differenti. Ogni opera è composta da due vetri accoppiati a una distanza di 12 mm: lo specchio frontale è retro-verniciato nei colori arancione, blu o rosso, mentre lo specchio posteriore riflette una geometria di giochi grafici in doppia prospettiva. La cornice smontabile consente la pulizia dello specchio ed è dotata di giunzioni visibili che esaltano il manufatto di falegnameria MedaMade. Le forme oblunghe, quadrate o rettangolari diversificano la proposta conferendole un senso di unicità artistica.

ENG

The mirrors making up the Deadline collection by Ron Gilad are ingeniously designed hybrid objects, combining premier engineering and carpentry skills of the highest order. Sixteen unique pieces, each set in its own black or white ashwood frame, each of which boasts a different texture and shape. Every piece is composed of two sheets of glass, 12mm apart. The front face is silvered, the back being coloured orange, blue, or red. These colours are reflected in the second mirror, to create a subtle interplay of graphic shapes. The frame comes apart so the mirrors can be cleaned. It is fitted with high-profile joints, the better to emphasise that this is an example of MedaMade craftsmanship. The oblong, square, or rectangular frames highlight the difference between each option, reinforcing the idea of the unique nature of the work of art.

DEU

Eine Spiegelkollektion, die von Ron Gilad gestaltet wurde. Hybride Objekte von baulicher Meisterhaftigkeit, bei denen Bautechnik mit hoher Tischlerkunst vereint wird. 16 einzigartige Exemplare, von denen jedes in einen Rahmen aus weißem oder schwarzem Eschenholz eingefügt ist und unterschiedliche Flächen und Formen aufweist. Jedes Meisterwerk besteht aus zwei Glasscheiben, die in einem Abstand von 12 mm vereint werden: Der Hintergrund des vorderen Spiegels ist in den Farben Orange, Blau oder Rot lackiert, während der rückseitige Spiegel eine Geometrie aus grafischen Spielen mit doppelter Perspektive widerspiegelt. Der abnehmbare Rahmen gestattet die Reinigung des Spiegels und verfügt über sichtbare Verbindungsstücke, die das Manufakt der Tischlerkunst MedaMade bereichern. Die länglichen, quadratischen oder rechteckigen Formen diversifizieren das Angebot und verleihen ihm ein Gefühl der künstlerischen Einzigartigkeit.

FRA

Une collection de miroirs et d'objets hybrides fruits d'une grande maîtrise artisanale. Conçue par Ron Gilad elle allie technologie de fabrication et haute ébénisterie. 16 exemplaires uniques, dont chacun est inséré dans un cadre en frêne, blanc ou noir, avec des surfaces et des formes différentes. Chaque pièce est composée de deux verres liés entre eux à une distance de 12 mm : le miroir frontal est peint au verso dans des teintes orange, bleu ou rouge, tandis que le miroir arrière présente une géométrie avec jeux graphiques en double perspective. Le cadre démontable permet de nettoyer le miroir et est équipé de joints visibles qui mettent en valeur le travail de menuiserie MedaMade. Les formes oblongues, carrées ou rectangulaires diversifient cette offre en lui donnant un sens d'unicité artistique.

- Cornice in legno massello di frassino, proposta in tre dimensioni (50x70, 40x170, 100x100 cm) e nelle finiture indicate a listino.
- Vetro di sicurezza extrachiaro, argentato e serigrafato nelle grafiche proposte a listino.
- Fissaggio a muro tramite piastrina metallica.

- Frames in solid ashwood, proposed in three sizes (50x70, 40x170, 100x100 cm), finishes as per pricelist.
- Safety extralight glass, silvered and serigraphed with graphic effects as per pricelist.
- Metal frame hanger.

- Rahmen aus Massivesche, in drei Größen (50x70, 40x170, 100x100 cm) und mit Finishlösungen laut Preisliste.
- Extrahelles Sicherheitsglas, versilbert und Siebdruck mit den Grafiken laut Preisliste.
- Wandbefestigung mit Metallplatte.

083 01/11

Who's Afraid of Red?

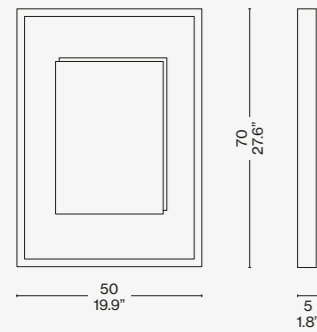

083 02/12

Memories of a Lost Oval

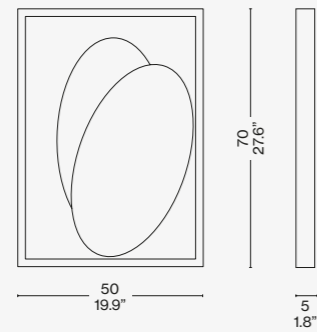

083 03/13

2 Crossing Paths

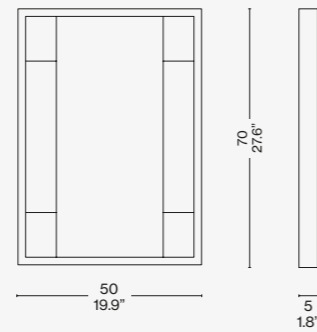

083 04/14

60 Crossing Paths

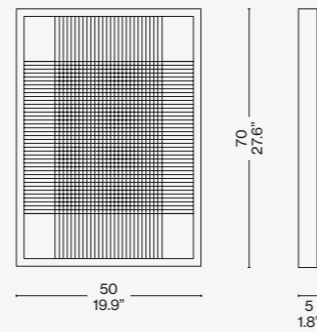

083 05/15

Shredded A3

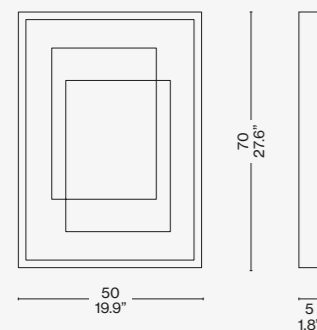

083 06

Daydream

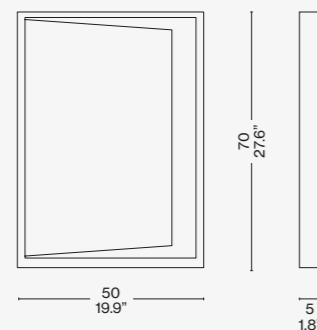

083 21/41

200 Lines of Realism

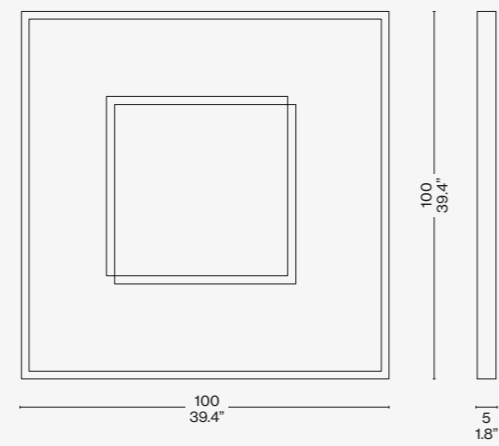

083 22/42

Eternal Sun

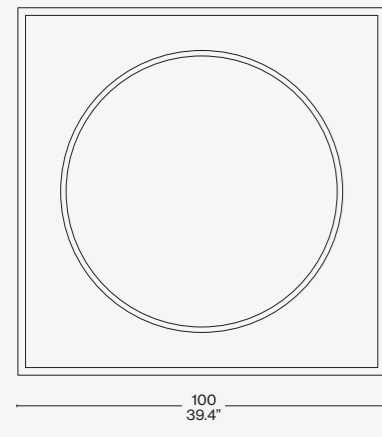

083 23/43

Reflections about Spatialism

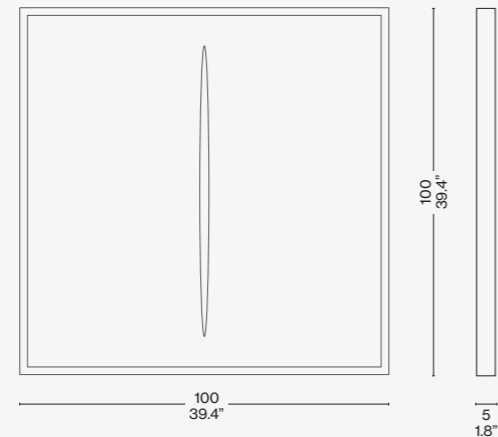

083 31/51

Cesare & Adele

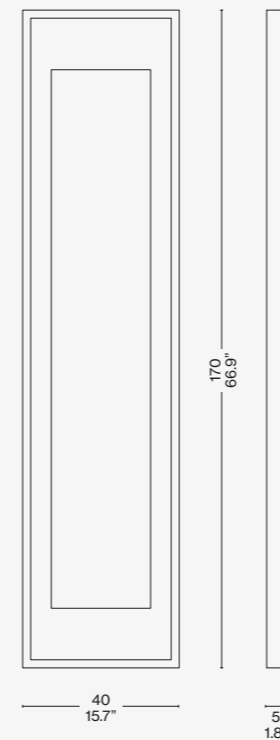

083 52

Sunset in Black

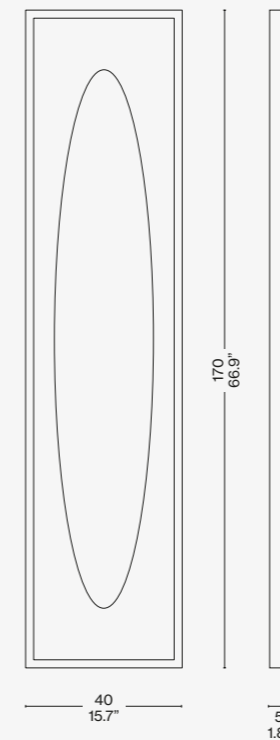

083 33/53

Blue Deadline

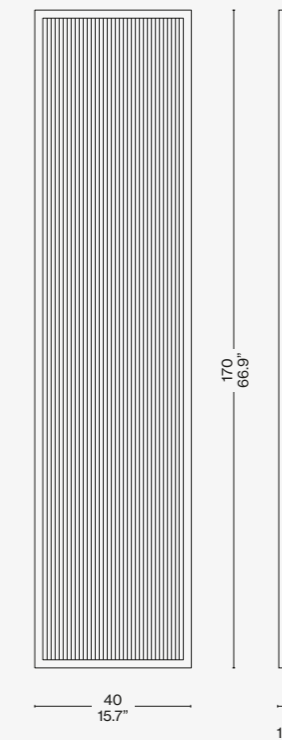

083 27/47

Quarto

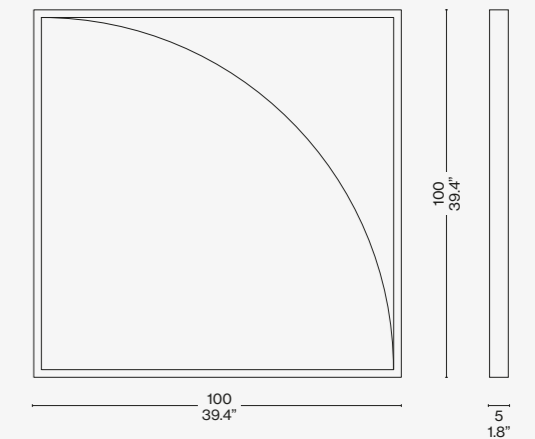

083 25/45

Oval void

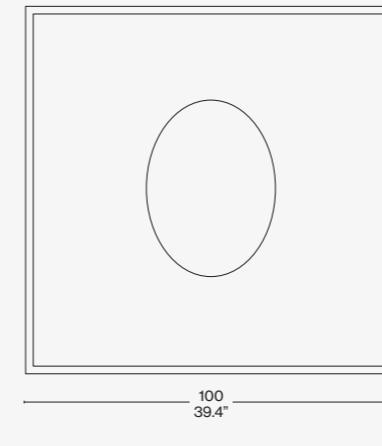

083 24/44

Oval dream

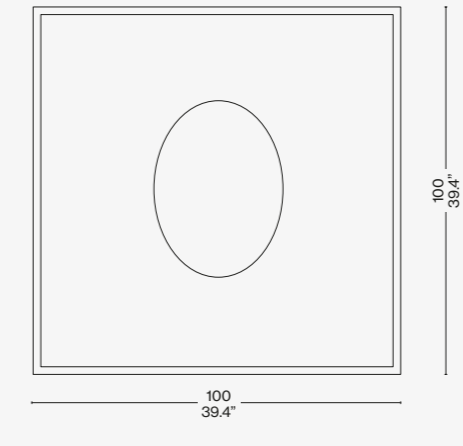

083 26/46

Mezzo

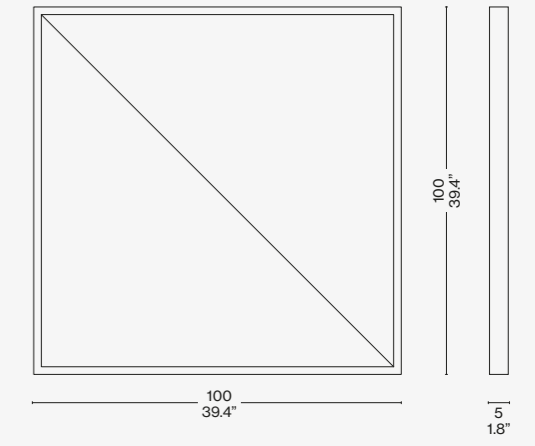

CONTEXT

ENQUIRIES
info@contextgallery.com

Tel. 404. 477. 3301
Tel. 800. 886.0867

contextgallery.com

Cornice/Frame/
Rahmen/Cadre

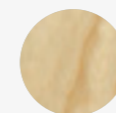

Frassino naturale/Natural ashwood/Esche
natur/ Frêne naturel

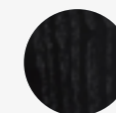

Frassino tinto nero/Ashwood stained
black/Esche schwarz gebeizt/Frêne
teinté noir