



Collezione "Cassina iMaestri"

Designed by

Le Corbusier, Pierre Jeanneret,
Charlotte Perriand, 1928

Fauteuil Grand Confort,
grand modèle

Produced

Cassina, 1965

ENQUIRIES
info@contextgallery.com

Tel. 404. 477. 3301
Tel. 800. 886.0867

contextgallery.com

LC3



ITA

Con LC3 la logica della modernità attua una separazione tra la struttura portante in metallo e gli elementi imbottiti, richiamando la relazione architettonica tra la struttura portante in cemento e gli elementi di tamponamento. In questo caso quattro cuscini, privi di legami, sono disposti in una gabbia di tubi di acciaio verniciato o cromato che costituisce il supporto primario del mobile in ogni sua tipologia, dalla poltrona con bracciolo singolo o doppio ai divani a due o tre posti. Nel corso degli anni Cassina ha collaborato a stretto contatto con Charlotte Perriand, con la sua erede e con la Fondazione Le Corbusier per introdurre nuove versioni e finiture che pur reinterpretando il progetto originale ne rispettano pienamente l'autenticità.

ENG

The LC3 armchair marked the separation of the metal frame from the upholstery, reflecting Modernist architecture theory, where the support load-bearing structure of the building was separated from the rest. In this case, four discrete cushions are set inside a cage of painted or chrome-finished steel tubes. The same device is adopted for all the other pieces in the collection, from the armchair with an arm-rest on one side only or on both, to the two- or three-seater sofas. Over a period of many years, Cassina worked closely with Charlotte Perriand, her heir, as well as with the Fondation Le Corbusier reinterpreting the original design while respecting its original intent, to bring new versions and finishes of this furniture to market.

DEU

Mit dem LC3 vollführt die Logik der Moderne eine Trennung zwischen der Tragestruktur aus Metall und den gepolsterten Elementen, wobei auf die architektonische Beziehung zwischen Tragestruktur aus Zement und dämpfenden Elementen verwiesen wird. In diesem Fall werden vier Kissen ohne jegliche Verbindung in einem Käfig aus lackierten oder verchromten Stahlrohren angeordnet, der die primäre Stütze des Möbelstücks in allen seinen Ausführungen darstellt, vom Sessel mit einer oder zwei Armlehnen bis zu den Zwei- oder Dreisitzersofas. Im Laufe der Jahre hat Cassina in engem Kontakt mit Charlotte Perriand, Le Corbusiers Erbin und der Fondation Le Corbusier zusammengearbeitet, um neue Versionen und Finishlösungen einzuführen, die das ursprüngliche Projekt zwar neu interpretieren, dabei jedoch dessen Authentizität voll und ganz respektieren.

FRA

Avec la ligne LC3, la logique de la modernité réalise la séparation entre structure porteuse métallique et éléments rembourrés, rappelant ainsi la relation architecturale qui joint la structure porteuse en ciment aux panneaux internes. Dans le cas de ces modèles, quatre coussins sans liens entre eux sont disposés dans une cage de tubes d'acier peint ou chromé qui constitue le support principal du meuble dans toutes ses typologies, du fauteuil à accoudoir simple ou double aux canapés à deux ou trois places. Au fil des ans, Cassina a travaillé en étroite collaboration avec Charlotte Perriand, avec son héritière et avec la Fondation Le Corbusier, afin de proposer de nouvelles versions et finitions qui, tout en réinventant le projet original, s'inscrivent pleinement dans la lignée de son authenticité.



1c



1d

Finiture/Finishes/
Ausführungen/Finitions



a

Pelle/Leather/Leder/Cuir Scozia
13X336 — Verniciato azzurro/Light blue
enamel/Hellblau lackiert/Laqué bleu



b

Pelle/Leather/Leder/Cuir Scozia
13X335 — Verniciato verde/Green
enamel/Grün lackiert/Laqué vert



c

Lipari 13L631 — Verniciato marrone/
Brown enamel/Braun lackiert/
Laqué marron



d

Pelle/Leather/Leder/Cuir Extra 13Y253
— Verniciato grigio/Grey enamel/
Grau lackiert/Laqué gris

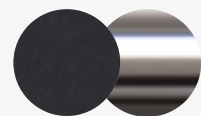

e/f

Pelle/Leather/Leder/Cuir LCX 13Y414 —
Cromato/Chrome plated/
Verchromt/Chromé

CONTEXT

ENQUIRIES
info@contextgallery.com

Tel. 404. 477. 3301
Tel. 800. 886.0867

contextgallery.com

e



f



Imbottitura: in poliuretano espanso schiumato e ovatta di poliestere/
Polyurethane foam and polyester padding/Polyurethanschaumstoff
und Polyesterwatte/ Rembourrage: mousse de polyuréthane
expansé et ouate de polyester

Imbottitura in piuma/Feather padding/Polsterkissen daunen/
Rembourrage en plume

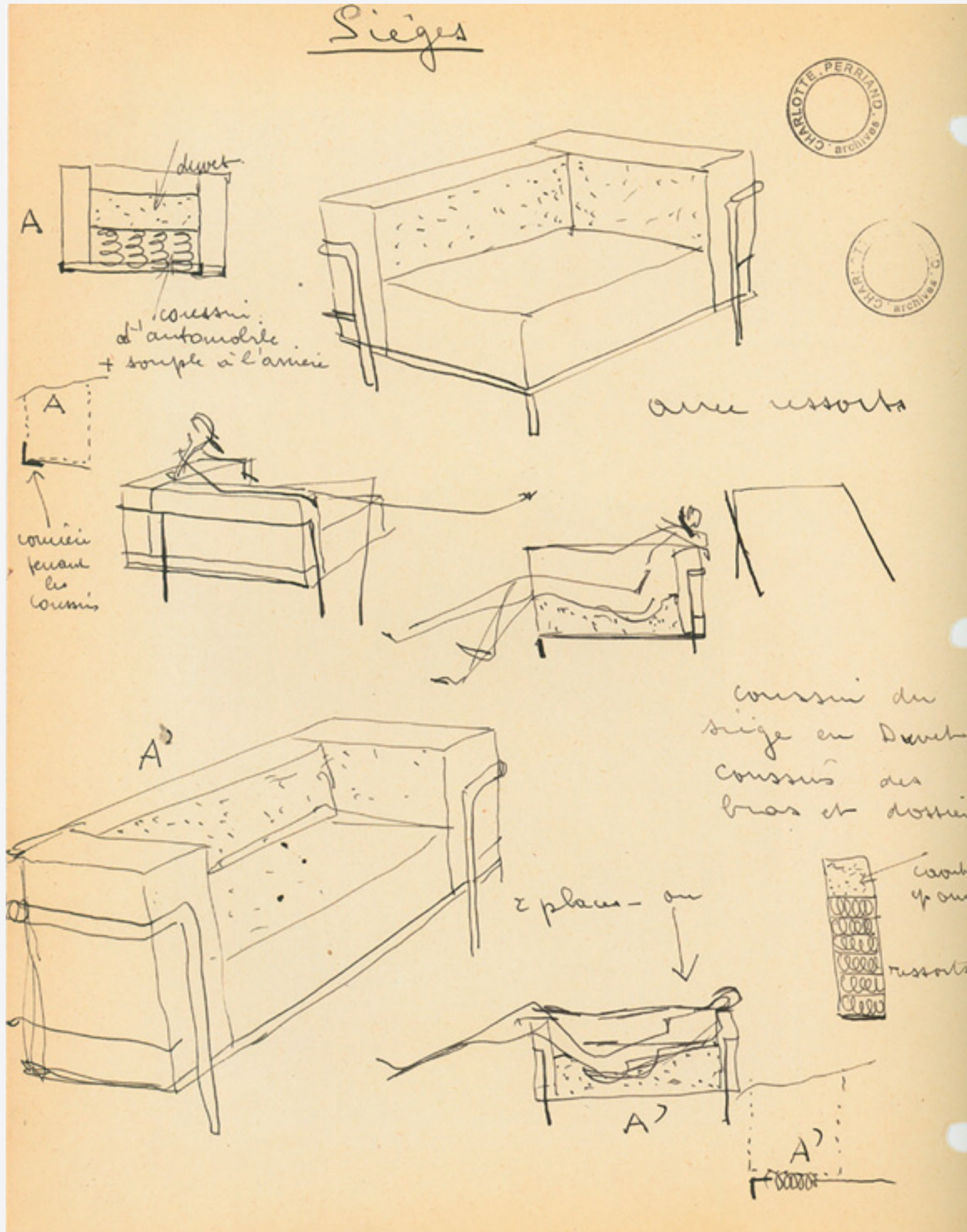

Research sketches of different versions of the Fauteuil Grand Confort©AChP/ADGP

Struttura
 · Telaio in tubolare d'acciaio.
 Finitura cromato lucido o verniciato nei colori indicati a listino.
 Imbottitura cuscini
 · Poliuretano espanso a densità differenziata.
 · Ovatta in fibra di poliestere resinata accoppiata con tela o piumino d'oca nella versione in piuma.
Rivestimento
 · Tessuto o pelle.
 Telaio seduta
 · In acciaio profilato angolare, cromato o verniciato nei colori elencati a listino e dotato di cinghiatura elastica.
Piedino
 · In materiale plastico con finitura nera.

Structure
 · Steel rod frame. Finishing polish chromium-plated or lacquered (colours as per price list).
 Cushions upholstery
 · Polyurethane foam in different density.
 · Resin polyester wadding coupled with cloth or eiderdown for the feather version.
 Quilted upholstery
 · Fabric or leather.
Seat frame
 · Corner profiled steel, chrome plated or lacquered (colours as per price list), with elastic belts.
Foot
 · In black finished plastic material.

Struktur
 · Rahmen aus Stahlrohr.
 Finish Chrom, glänzend oder lackiert in den Farben laut Preisliste.
 Polsterung Kissen
 · Polyurethanschaum mit unterschiedlicher Dichte.
 · Gehärzte Polyesterfaserwatte mit Beschichtung aus Gewebe oder Gänsedaunen in der Daunenversion.
Bezug
 · Stoff oder Leder.
Rahmen Sitzfläche
 · Aus winkeligem Profilstahl, verchromt oder lackiert in den Farben laut Preisliste, mit elastischen Riemen.
Füßchen
 · Aus Kunststoffmaterial mit schwarzem Finish.

CONTEXT

ENQUIRIES
 info@contextgallery.com

Tel. 404. 477. 3301
 Tel. 800. 886.0867

contextgallery.com
 contextcontract.com

003 1_/E_

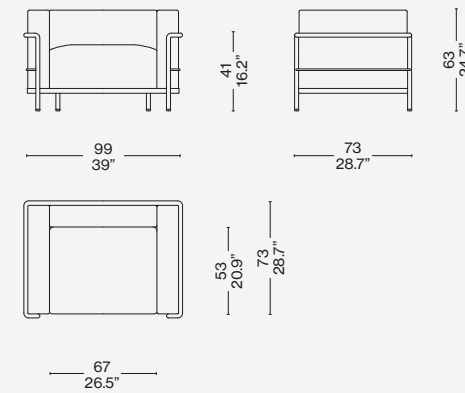

003 2_/F_

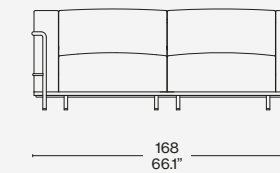

003 A_/G_

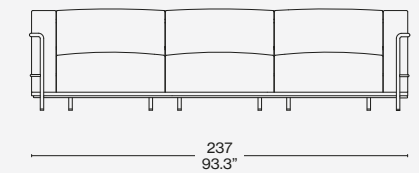

003 B_/H_

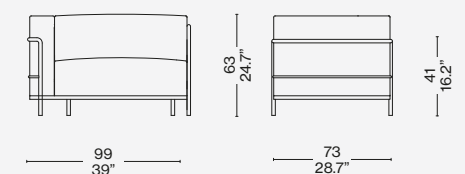

003 C_/L_

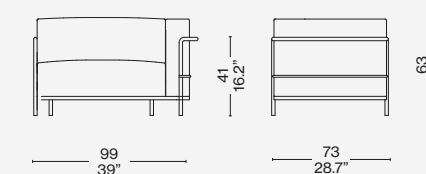

Identifying marks and production numbers

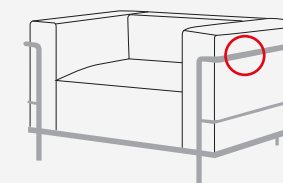

Cassina LC P.J. CP   LC3 N° _____ Le Corbusier G. Jeanneau Ch. Rossetti