

LC6 Table

Designed by Le Corbusier, Charlotte Perriand, Pierre Jeanneret

The LC6 table was originally designed as a dining table for the Villa Church in 1928 and paired with the LC7 swivel chairs. The LC6 table was first exhibited by the designers at the 1929 Salon d'Automne; production through Cassina began in 1974. It features a base comprised of two rectilinear sides with a central horizontal brace that spans the length of the base. The base composition is in broad, elliptical shaped tubular steel that is expertly mitered at the angles to create the illusion of a seamless form. To ensure the base is enjoyed from a number of vistas, it is paired with a rectilinear glass top that is joined to the base by four steel threaded shanks that separate the glass from the base - creating the illusion that the tabletop is floating above the base. The shanks are adjustable and permit the user to establish the distance between the glass top and the base to a maximum of 1.8". The LC6 table is perfect as a dining table or large desk/work surface; similarly an excellent choice as a small conference table.



Extra Clear Glass

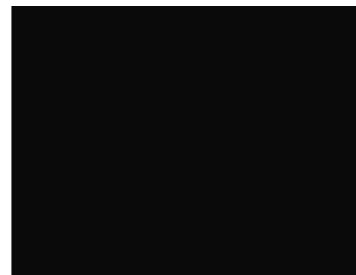

Matt Black



available combinations

- LC6 with extra clear glass top and matt black painted base

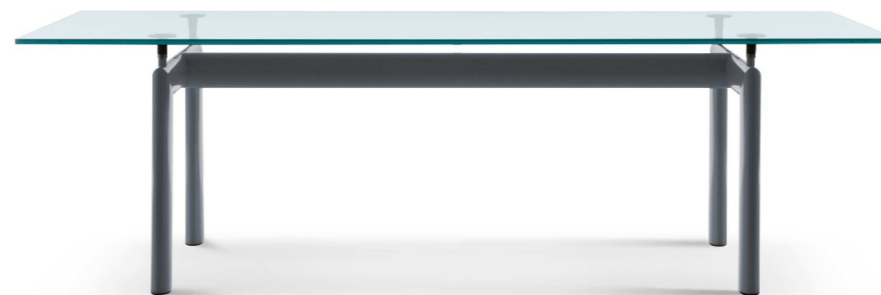

available compositions

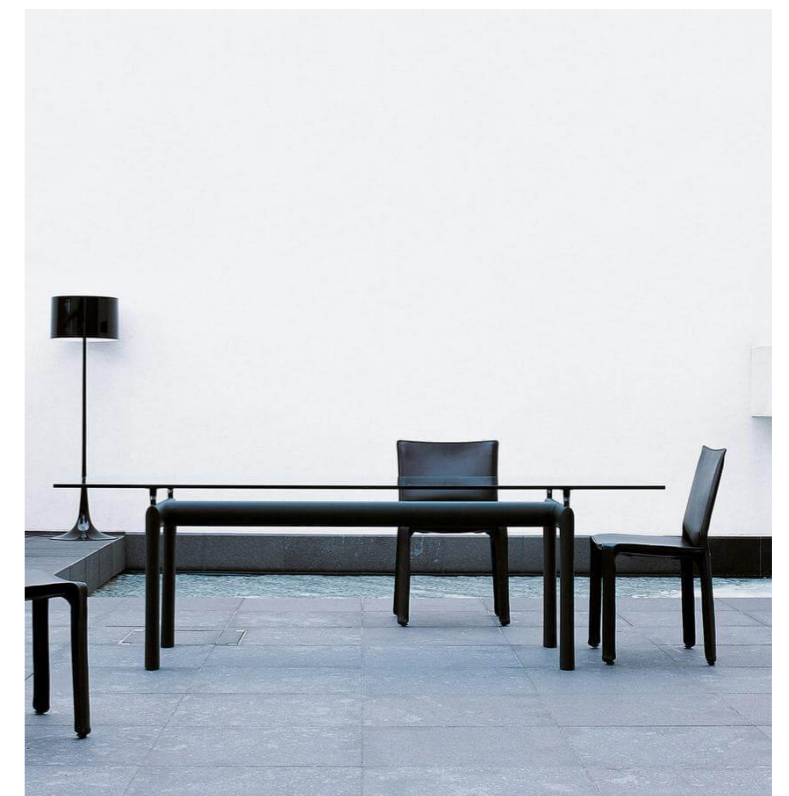
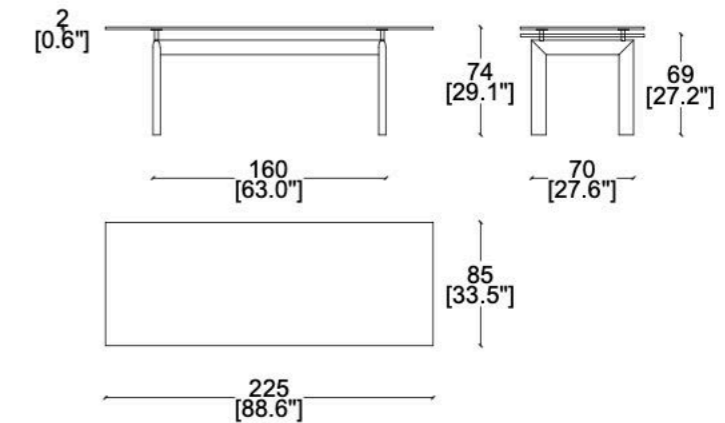

CONTEXT GALLERY

ENQUIRIES
info@contextgallery.com

Tel. 404. 477. 3301
Tel. 800. 886.0867

contextgallery.com

Cassina