

Round Chair / The Chair

Design: Hans J. Wegner, 1949/1950

pp501 | pp503

ENQUIRIES
info@contextgallery.com
Tel. 404. 477. 3301
Tel. 800. 886.0867
contextgallery.com



Essential Danish modernism

The Round One as Wegner referred to it with his usual provincial modesty, is one of the most famous Danish pieces of furniture – certainly the most distinctly Danish. In its own modest and simple way it sums up the very essence of traditional Danish woodworking and design philosophy. And it is absolutely the most important work of Hans J. Wegner.

With this chair Wegner came into his own right, no longer needing the inspiration from other cultures and designers that had influenced his earlier works. This chair was created in a language of shape and construction that only Wegner spoke and it triggered the first ever, foreign report on Danish design in the American Interiors Magazine.

It also became the cornerstone in a wide range of designs, which for more than a decade constituted the core business of several Danish furniture manufacturers, effectively becoming the main force in the great international breakthrough of Danish Modern.

Wegner evaluated the Round Chair in this way: "Personally, I think it's my best achievement. Not because of its export success, but because I have been more thorough with it than anything else."





The prototype of the Round Chair was featured in the US magazine Interiors in 1950. This was the first ever report on Danish furniture outside Denmark and the following text accompanied a picture of the chair,

“In this oak desk chair Mr. Wegner uses a simple construction and devotes himself to perfecting the shape and scale of the parts.

The top rail, a complicated collection of twisted curves and joints, was wrested into quiet obedience.

The sturdy legs are tapered just enough to seem muscular rather than overfed and the seat dips slightly to look willing but not seductive.”

The Round Chair became one of the most desired designs on the American market and the export of Danish furniture quickly picked up. Within the American furniture business the Round Chair was regarded as an archetype of a modern chair and it became known simply as “The Chair”.

When John F. Kennedy and Richard Nixon met in the first ever, televised election debate in 1960, they sat in the Round Chair. It constituted a clear statement of modernism that underlined the significance of this historic broadcast event.

The Round Chair conveyed comfort and genuine quality – made in Denmark and shipped to the USA to play an important role as an individual companion for each candidate in their aspiration for the highest office. Eventually the Americans came up with a new and more telling name for this chair. They called it The Chair.

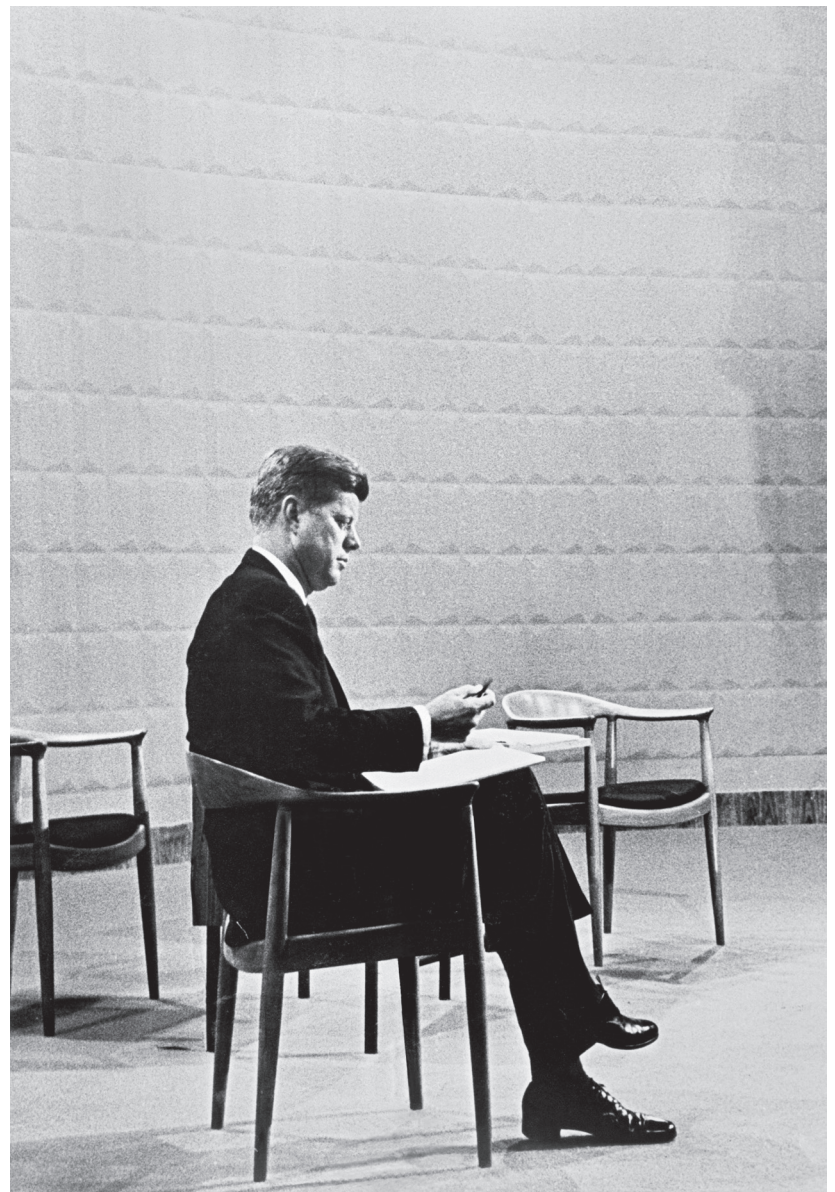

Carved from shelter trees

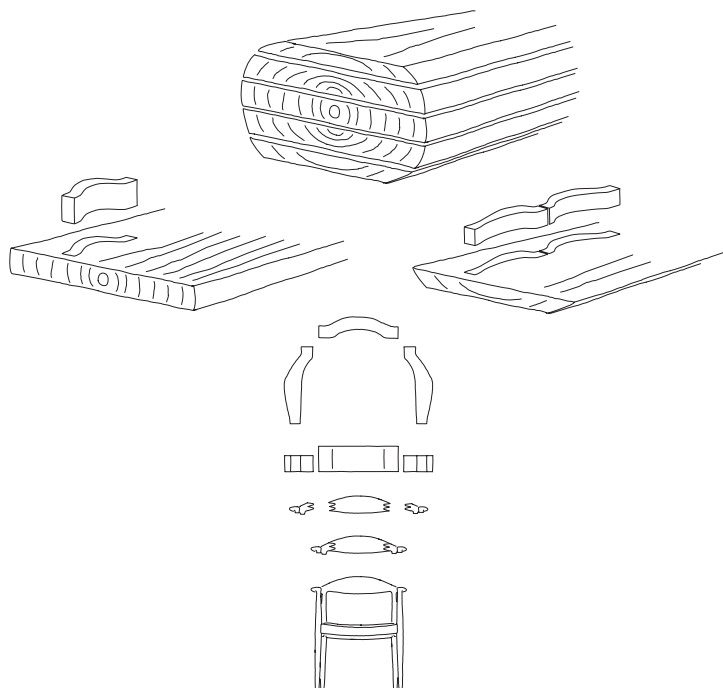

The armrest for the pp501 | pp503 Round Chair consists of three pieces each carved out of solid wood from a shelter tree approximately 200 years old. Each piece is cut into rough dimensions from a fresh newly felled tree. The right and left armrests are cut in line with one another and paired to match.

The raw parts are then conditioned for between one and two years depending on the wood type. This is a delicate process that cannot be hurried and there is no technology that can speed up the conditioning process. We have to rely on the nature of the tree and on generations of experience.

If sales exceed the amount of parts cut and conditioned, the lead time of a new chair will be entirely dependent on the conditioning process and availability of shelter trees.

Round Chair / The Chair

pp501 | pp503

Design: Hans J. Wegner, 1949/1950





Round Chair / The Chair

pp501 | pp503

Design: Hans J. Wegner, 1949/1950

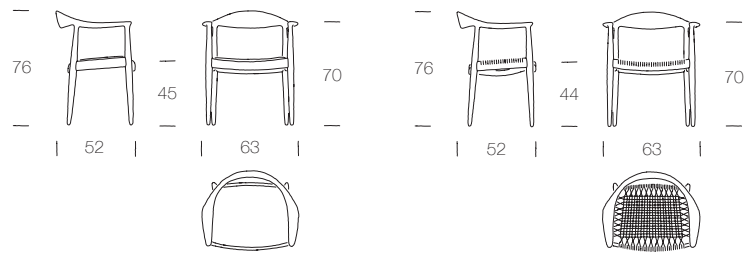

The back of the pp501 | pp503 is carved out of a 5 inch piece of solid wood.

pp501 | pp503 comes in oak, ash, cherry or walnut. Oil or lacquer is available for all materials. Oak and ash are also available soaptreated.

pp501 comes with seat in nature or light cane. The material used in caning chairs is derived from the peeled bark of the rattan vine. It looks somewhat similar to bamboo but is much more flexible. It is very beautiful, but also very delicate and it needs some maintenance to stay smooth because should the cane dry out it may split.

pp503 comes with upholstered seat.



pp møbler

Vestvej 45
3450 Allerød
Denmark

info@pp.dk
www.pp.dk

“ Many foreigners have asked me, how we created the ‘Danish Modern’ style. And I have to say that it was nothing like that – creating ...

I suppose it was more an advanced process of purifying and for me simplification, cutting the elements down to the bare essentials:

Four legs, a seat and a combined back and arm rest – The Chair.”

