

# Cow Horn Chair

Design: Hans J. Wegner, 1952

pp505

ENQUIRIES  
[info@contextgallery.com](mailto:info@contextgallery.com)

Tel. 404. 477. 3301  
Tel. 800. 886. 0867

[contextgallery.com](http://contextgallery.com)



## Playing with contrast

Great luxury sometimes comes in small packages. This is one of Wegner's smallest chairs, but it is an amazing work of art.

Designed in 1952 the Cow Horn Chair is the immediate follow up on the breakthrough of Wegner's career, pp501 | pp503 Round Chair. The continuity in shape and philosophy is obvious but designed for a different purpose, Wegner created a smaller chair that would easily fit underneath the table thus making it more suitable for the dining set.

Wanting to pay homage to the breathtaking beauty of solid wood manually carved into organic shapes, Wegner decided to make a compact chair.

Hence the number of pieces of solid wood used to form the armrests and back was reduced to only two pieces, joined in the middle.

The joint obviously needs to be aligned with the grains of the wood with some kind of tenon and could be dowelled but in this case Wegner decided that he would rather enhance it and make it a decorative feature of the design. To obtain the full visible effect, Wegner used wood of a contrasting colour.

This original idea would later become a characteristic trademark in many of his works and it is an important example of his honest and craftsman-like approach to design.







## Joint details in contrasting wood

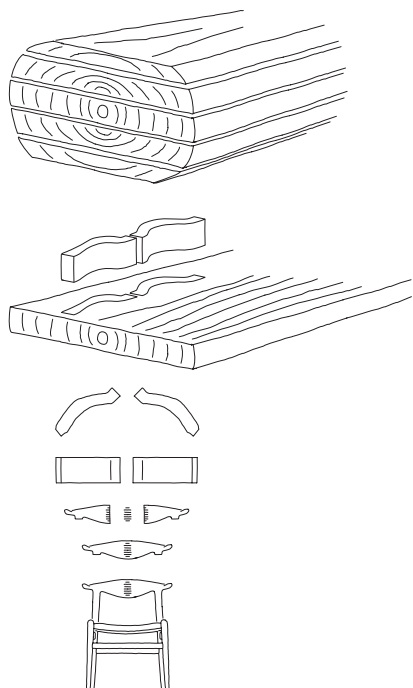

The pp505 Cow Horn Chair is a compact chair developed by Wegner along the theme of the Round Chair. The armrest consists of only two pieces of solid wood each carved from shelter trees of around 200 years old. The right and left armrests are always cut in line of one another and paired to match.

The right and left armrests are joined in the centre of the back where the wood is thickest, facing end-grain to end-grain. Gluing surfaces together along the end-grain of wood is technically very difficult making for a weak joint that moves over time.

Wegner resolved this problem on the Cow Horn Chair by using contrasting wood tenons that makes the necessary constructional detail both strong and beautiful. The tenons serve to centre the design of the chair giving visual harmony when cow horns are grouped together.

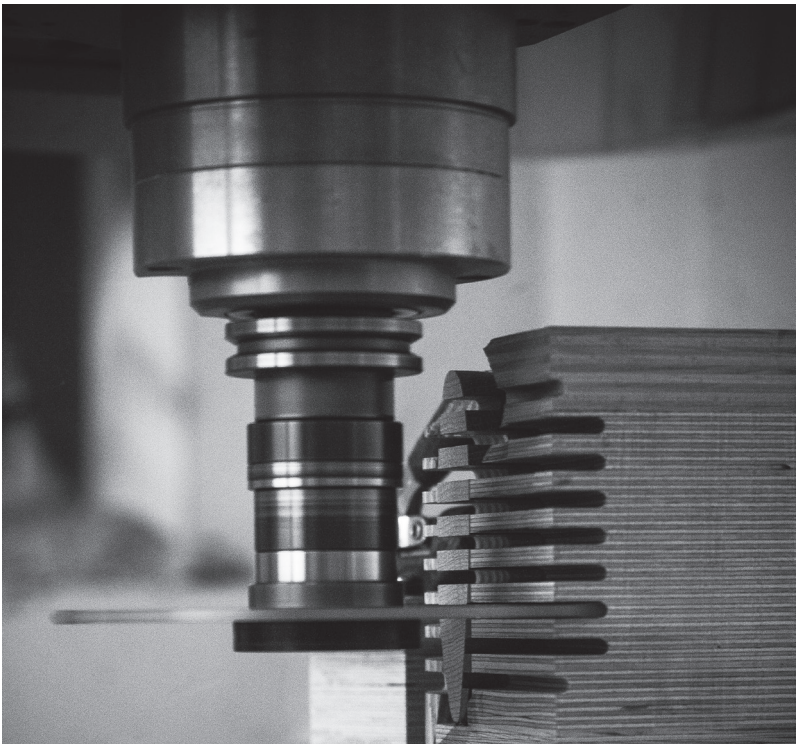





# Cow Horn Chair

Design: Hans J. Wegner, 1952

pp505

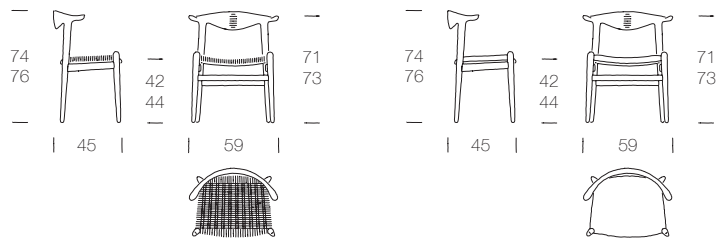

pp505 is available with either cane or upholstered seat. As opposed to most other chairs by Wegner, this chair is upholstered directly on the seat rails.

Before the era of Wegner this was the normal way of upholstering chairs and in the case of the Cow Horn Chair and the Bull Chair, Wegner sticks to the old tradition.

The armrests on pp505 are always cut from the same piece of wood, so the grain will match. The joint detail in the back is made of rosewood.

pp505 comes in oak, ash or cherry. Oil or lacquer is available for all materials. Oak and ash are also available soaptreated.





pp møbler

Vestvej 45  
3450 Allerød  
Denmark

info@pp.dk  
www.pp.dk

