

## Tub Chair

Design: Hans J. Wegner, 1954

pp530

ENQUIRIES  
info@contextgallery.com

Tel. 404. 477. 3301  
Tel. 800. 886.0867

contextgallery.com



## A daring concept



Conceived in 1954 the **Tub Chair** was a pioneering experiment and it turned out to be the most advanced shell chair design Wegner created as the back of the chair is a complicated double bent shell comprising of two individual shapes. One that is bent and one that is both bent and twisted.

Even besides the complexity of the back, the **Tub Chair** is a unique fusion, where Wegner merged the moulded plywood technique with upholstery and traditional work in solid wood, even adding a metal angle adjustment mechanism for the back.

It is one of the most striking and brilliant examples of Wegner's vision and courage and it is a most practical, usable and comfortable chair. It was not, however, technically possible to produce the **Tub Chair** in a rational way during the lifetime of Wegner. As our techniques have developed, PP Møbler has been able to produce this great tribute and introduce this bold design in celebration of the 100 years anniversary of Wegner.

# Tub Chair

Design: Hans J. Wegner, 1954

pp530

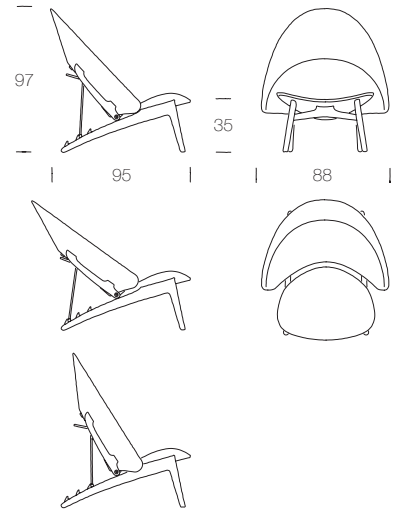

The back is adjustable and can be placed in three different positions. Upright for reading and conversation, in a classic easy chair position and in a laid back position for relaxing.

## Double bent wooden shells

Moulding shells of wood is a part of laminating technology. Gluing layers of veneer makes it possible to produce large curved constructions that are light and strong. At PP Møbler we use this technique for making the seats for upholstery.

In the 1940's and 50's leading designers like Ray & Charles Eames, Alvar Alto and Arne Jacobsen created some highly innovative and iconic chairs exploring the full potential of this technique. They all had to comply with the limitation that veneer, like paper, can only be bent in one direction at a time. It is by principle impossible to make a double bent shell made of veneer.

Wegner challenged this principle in 1954, when he created the **Tub Chair**. The concept of the back shell was daring and as Wegner combined it with upholstery, fine woodwork and even an elegant metal mechanism to adjust the angle of the back, he created an iconic chair unlike anything else. At that time the **Tub Chair** was impossible to produce and only a few prototypes were made.

In 2003 the 3D veneer technique was introduced. By slicing up the veneer into 1 millimetre wide strips it is now possible to bend wood shells in two directions. The **Tub Chair** finally made it into production in 2014.

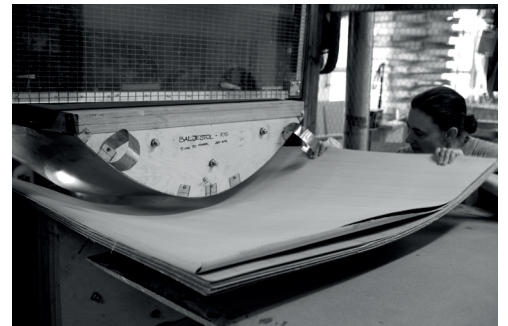

pp møbler

Vestvej 45  
3450 Allerød  
Denmark

info@pp.dk  
www.pp.dk

